

# KUBOTA WHEEL LOADER RT280-2

For Earth, For Life  
**Kubota**



Engine output:  
**50 HP / 36 kW**



Machine weight:  
**2800 / 2950 kg**

## Standard equipment

Kubota Engine D1803 Stage V (CR - DOC - DPF)

Tyres 11.5/80-15.3 AS (Total width 110 cm)

Hydrostatic Transmission 4 wheel drive with automotive control

12 tons planetary axles (HD version) with 28.000 N pulling force

100% electrical differential lock on both axles

Electric shuttle on joystick

Lifting arm and tilt controlled by joystick

Double acting mechanical auxiliary circuit AUX1

Floating position

ROPS / FOPS canopy included safety doors

Deluxe seat with safety belt, armrest and extended backrest

Battery main switch

Towing hook at the back

Working light (halogen) front and on lifting arm

Cyclone filter

Oil Cooler

Hydraulic quick coupler

Drum brakes



# Specifications

For Earth, For Life



Model name		RT280-2	
Engine	Make	Kubota	
	Model	D1803 CR	
	Displacement	CC	1826
	Output	HP(kW)	50 (36)
Service weight		kg	2800
Tipping load		kg	2900
Driving speed	1°st speed	km/h	0~15
	2°nd speed	km/h	0~30
Lifting capacity	A	kg	3000
	B	kg	2200
	C	kg	1600
Auxiliary circuit	Oil flow	l/min	51
	Oil pressure	bar	230

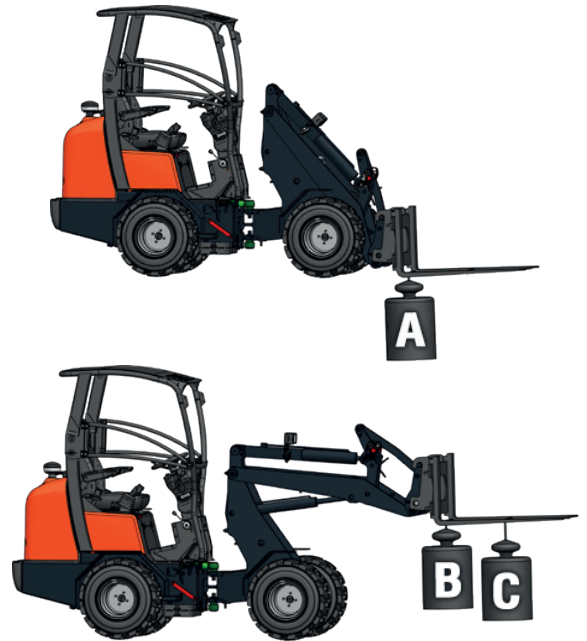

# Dimensions

Model name		RT280-2	
A	Wheel base	mm	1648
B	Overall length	mm	3405
C	Overall height with canopy	mm	2340
C'	Overall height with cabin	mm	2363
D	Overall width	mm	1273
E	Height front frame	mm	1513
F	Max. dumping height	mm	1753
G	Max. bucket pin height	mm	2517
H	Height with bucket	mm	3105

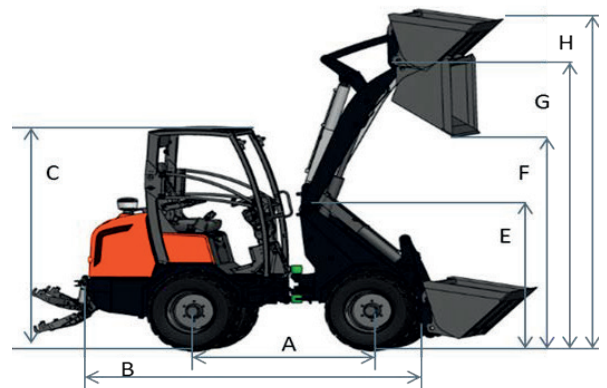

# Accessories



Earth bucket



Bucket 4 in 1

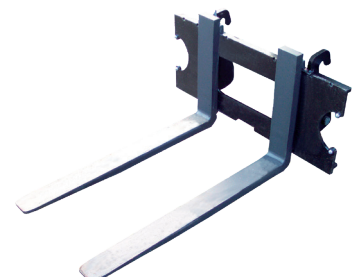

Pallet fork

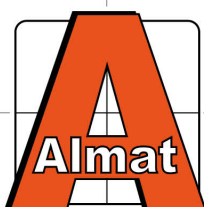

**INDUSTRIE | GROENTECHNIEK | LANDBOUW | VERHUUR**

Stoomdijk 13 - 15 T. 0573 - 44 80 80  
7245 PN Laren Gld. info@almatlaren.nl

**WWW.ALMATLAREN.NL**