

# KUBOTA WHEEL LOADER RT160-2

For Earth, For Life  
**Kubota**



Engine output:  
**26 HP / 19 kW**



Machine weight:  
**1525 / 1730 kg**

## Standard equipment

- Kubota Engine D1105 Stage V
- Tyres 26 x 12.00-12 AS (Total width 110 cm)
- Hydrostatic Transmission 4 wheel drive with automotive control
- Driving system with 4 hydraulic wheel motors Poclain
- 100% differential lock on request
- Electric shuttle on joystick
- Lifting arm and tilt controlled by joystick
- Auxiliary circuit 1 mechanically operated with lever behind the joystick
- Floating position
- ROPS / FOPS canopy included safety doors
- Deluxe seat with safety belt, armrest and extended backrest
- Battery main switch
- Towing hook at the back
- Working light (halogen) front and on lifting arm
- Cyclone filter
- Oil Cooler
- Hydraulic quick coupler
- Hydraulic multidisk brake - Electric controlled



## Specifications

Model name		RT160-2	
Engine	Make	Kubota	
	Model	D1105	
	Displacement	CC	1123
	Output	HP(kW)	26 (19)
Service weight		kg	1525
Tipping load		kg	1500
Driving speed		km/h	0~12
Lifting capacity	A	kg	1500
	B	kg	1100
	C	kg	750
Auxiliary circuit	Oil flow	l/min	45
	Oil pressure	bar	170

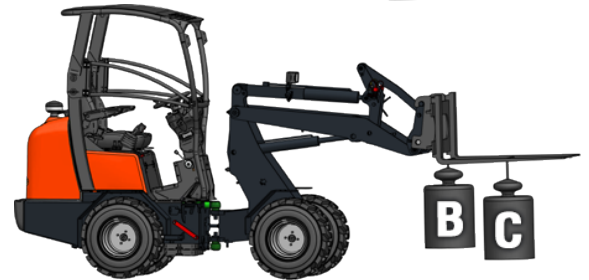

## Dimensions

Model name		RT160-2	
A	Wheel base	mm	1419
B	Overall length	mm	2718
C	Overall height with canopy	mm	2230
D	Overall width	mm	1100/1240
E	Height front frame	mm	1148
F	Max. dumping height	mm	1360
G	Max. bucket pin height	mm	2067
H	Height with bucket	mm	2641

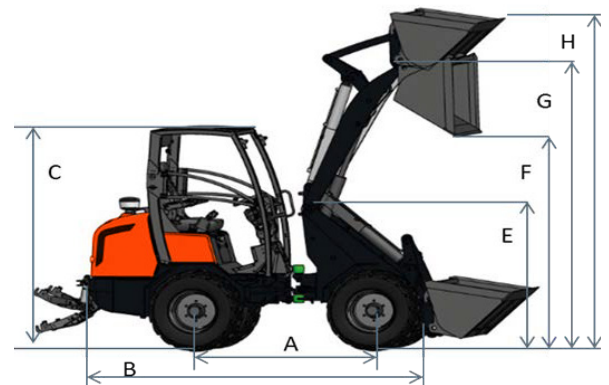

## Accessories



Earth bucket



Bucket 4 in 1

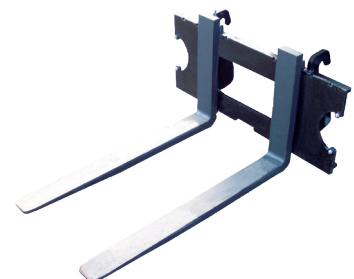

Pallet fork

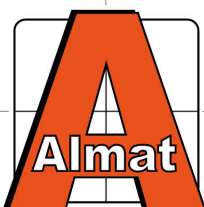

**INDUSTRIE | GROENTECHNIEK | LANDBOUW | VERHUUR**

Stoomdijk 13 - 15 T. 0573 - 44 80 80  
7245 PN Laren Gld. info@almatlaren.nl

**WWW.ALMATLAREN.NL**