

# KUBOTA WHEEL LOADER RT250-2

For Earth, For Life  
**Kubota**



Engine output:  
**26 HP / 19 kW**



Machine weight:  
**2400 / 2550 kg**

## Standard equipment

- Kubota Engine D1505 Stage V
- Tyres 11.5/80-15.3 AS (Total width 110 cm)
- Hydrostatic Transmission 4 wheel drive with automotive control
- 8 tons planetary axles with 18.000 N pulling force
- Limited slip on both axles
- Electric shuttle on joystick
- Front attachment controlled by joystick
- Double acting mechanical auxiliary circuit AUX1
- Floating position
- ROPS / FOPS canopy included safety doors
- Deluxe seat with safety belt, armrest and extended backrest
- Battery main switch
- Towing hook at the back
- Working light (halogen) front and on lifting arm
- Cyclone filter
- Oil Cooler
- Hydraulic quick coupler
- Drum brakes



# Specifications

For Earth, For Life



Model name		RT250-2	
Engine	Make	Kubota	
	Model	D1505	
	Displacement	CC	1123
	Output	HP(kW)	26 (19)
Service weight		kg	2400
Tipping load		kg	2050
Driving speed	1°st speed	km/h	0~10
	2°nd speed	km/h	0~20
Lifting capacity	A	kg	2525
	B	kg	1580
	C	kg	1100
Auxiliary circuit	Oil flow	l/min	40
	Oil pressure	bar	210

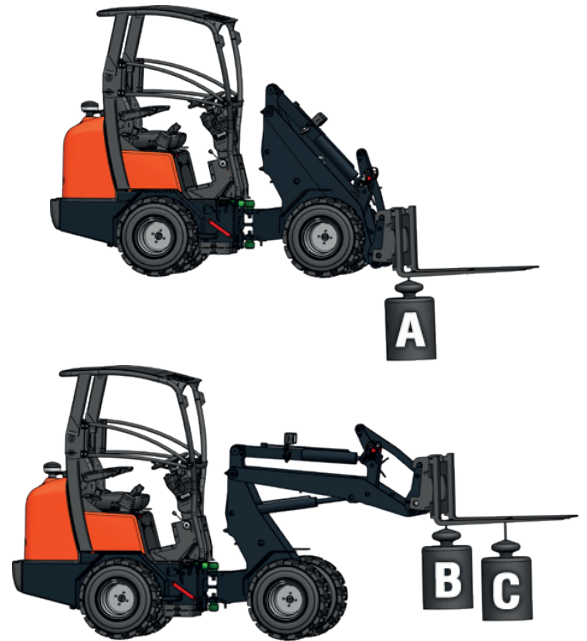

# Dimensions

Model name		RT250-2	
A	Wheel base	mm	1643
B	Overall length	mm	3247
C	Overall height with canopy	mm	2322
C'	Overall height with cabin	mm	2345
D	Overall width	mm	1100/1360
E	Height front frame	mm	1731
F	Max. dumping height	mm	2144
G	Max. bucket pin height	mm	2964
H	Height with bucket	mm	3532

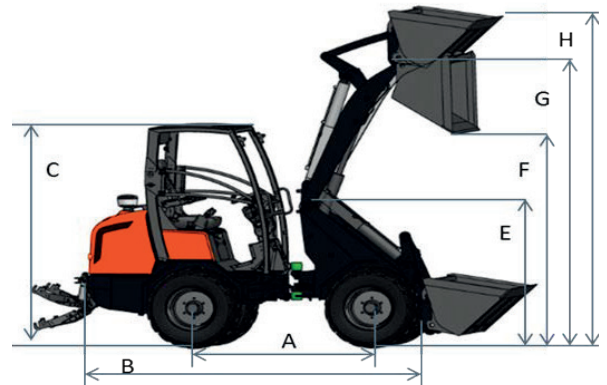

# Accessories



Earth bucket



Bucket 4 in 1

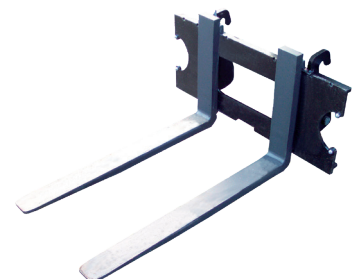

Pallet fork

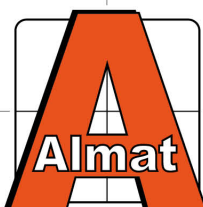

**INDUSTRIE | GROENTECHNIEK | LANDBOUW | VERHUUR**

Stoomdijk 13 - 15 T. 0573 - 44 80 80  
7245 PN Laren Gld. info@almatlaren.nl

**WWW.ALMATLAREN.NL**